

# n°rdweld. Tack weld stand

## Tack weld configuration

The horizontal joint is aligned while the tank is continuously rotated. This means that the tack welding is very simple, fast and extremely cost effective. When attaching any required stiffening rings, the stand is also used to fix each individual ring segment to the shell plate.

## Weld configuration

The stand is equipped with a track which enables a totally autonomous mechanized welding process of both the vertical and horizontal weld seams. It is also possible to use this device to fillet weld required stiffening rings to the outer shell. It can be used with all common industrial welding methods designated by the customer.

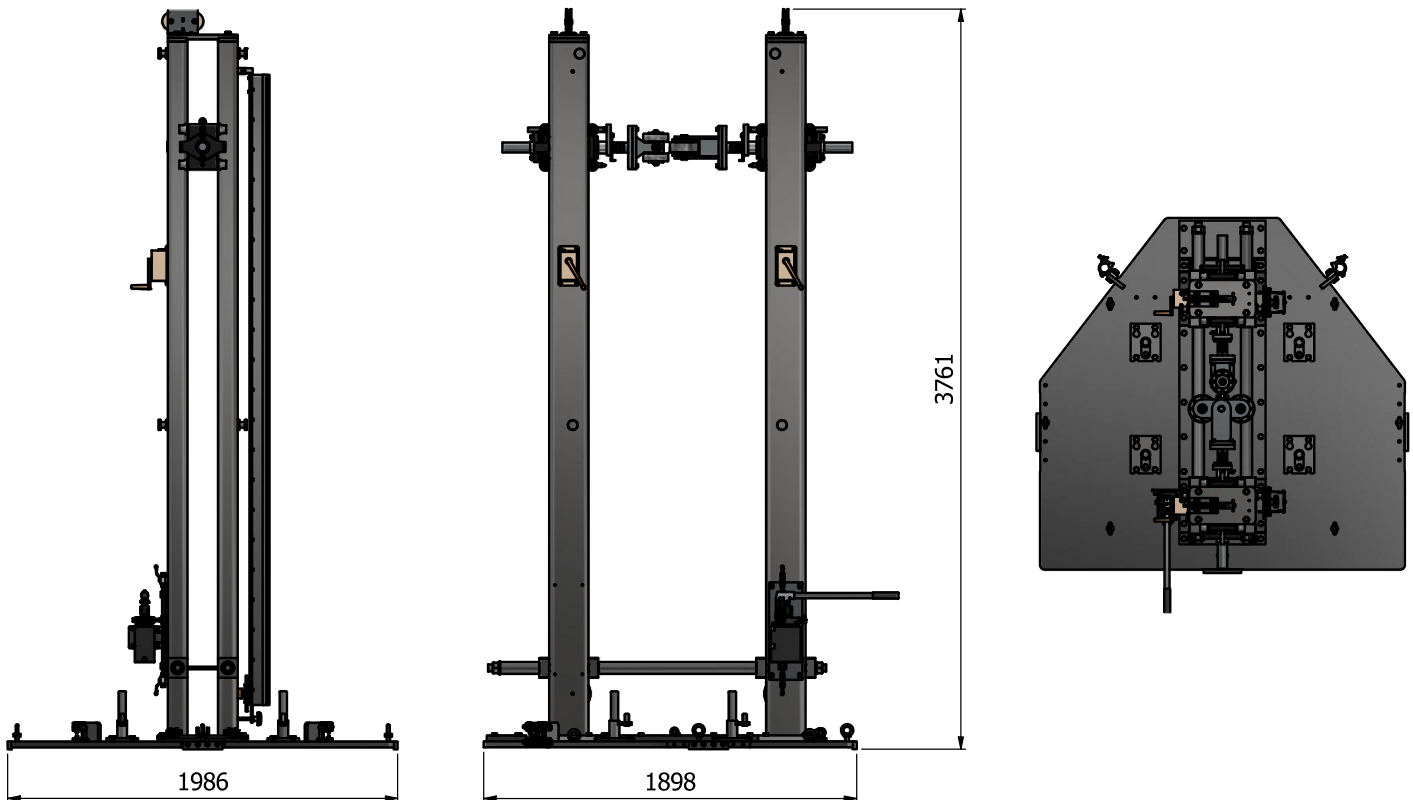
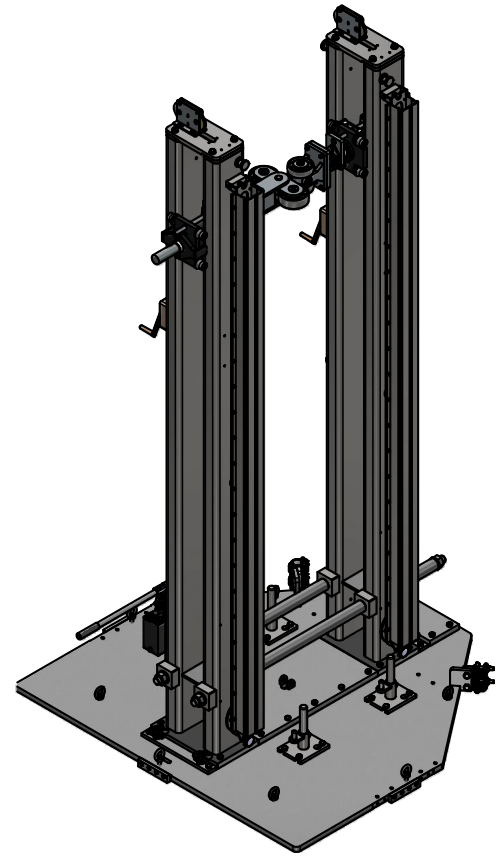

Nordweld Sp. z o.o. registered in: XII Commercial Division of the National Court Register District Court for Krakow - Śródmieście in Krakow; share capital in the amount of PLN 10 000,00 PLN.

Nordweld Tank Building System AB  
Box 52  
891 22 Örnköldsvik  
Sweden

Nordweld Production Plant  
ul. Przemysłowa 3  
38-300 Gorlice  
Poland

+46 738 183 444  
+48 600 151 551  
info@nordweld.eu  
nordweld.eu

Company registration No: 559082-3539  
TAX ID No: SE-559082353901  
PL-7382153047  
IBAN No: PL38 1090 2590 0000 0001 4722 2227  
BIC Swift: WBKPPLPP  
REGON: 368373807  
KRS: 0000696764

Member of **TLC** Group  
+ 48 505 140 140  
info@tlc.eu  
tlc.eu